



TFT MODULE SPECIFICATION

RVT70HSTNWN00 V1.1A

IPS RGB 7.0” display datasheet
Rev. 1.0
2026-05-15

Riverdi Sp. z o.o.

Nowy Swiat 36
80-299 Gdansk, Poland
VAT ID: PL5842767153
Registration number (KRS): 0000923967

+48 587 703 116

Office hours: 9:00 to 17:30 CET (Mon-Fri)

contact@riverdi.com

riverdi.com



ITEM	CONTENTS	UNIT
LCD Type	TFT/Transmissive/Normally black/IPS	/
Size	7.0	Inch
Viewing Direction	Free	/
Outside Dimensions (W x H x D)	164.90 x 100.00 x 5.56	mm
Active Area (W x H)	154.21 x 85.92	mm
Pixel Pitch (W x H)	0.1506 x 0.1432	mm
Resolution	1024 (RGB) x 600	/
Brightness	1000	cd/m ²
LCD Interface Type	RGB	/
Color Depth	16.7 M	/
Pixel Arrangement	RGB Vertical Stripe	/
LCD Driver	EK79001HK+EK73215BCGA	/
With/Without Touch	Without Touch Panel	/
LCD Input Voltage	3.3	V
Weight	TBD	g

Note 1. RoHS3 compliant

Note 2. LCM weight tolerance: $\pm 5\%$.

1. REVISION RECORD

REV NO.	REV DATE	CONTENTS	REMARKS
1.0	2026-05-15	Initial release	

2. CONTENTS

1.	REVISION RECORD	3
2.	CONTENTS	4
3.	MODULE CLASSIFICATION INFORMATION	5
4.	MODULE DRAWING	6
5.	ABSOLUTE MAXIMUM RATINGS	7
6.	ELECTRICAL CHARACTERISTICS	7
7.	BACKLIGHT ELECTRICAL CHARACTERISTICS	8
8.	ELECTRO-OPTICAL CHARACTERISTICS	9
9.	INTERFACES DESCRIPTION	12
9.1	TFT ASSIGNMENT	12
10.	TIMING CHART	13
10.1	Vertical Input Timing	13
10.2	Horizontal Input Timing	14
10.3	Parallel RGB Timing Characteristic	14
10.3.1	DE Mode	14
10.3.2	HV Mode (Horizontal input timing)	15
10.3.3	HV Mode (Vertical input timing)	15
11.	INSPECTION	15
12.	RELIABILITY TEST	16
13.	LEGAL INFORMATION	17
14.	CONTACT	18

3. MODULE CLASSIFICATION INFORMATION

RV	T	70	H	S	T	N	W	N	00	V1.1A
1.	2.	3.	4.	5.	6.	7.	8.	9.	10.	11.

NO.	PARAMETER	SYMBOL
1.	BRAND	RV - Riverdi
2.	PRODUCT TYPE	T - TFT Standard
3.	DISPLAY SIZE	70 - 7.0"
4.	MODEL SERIAL NO.	H - High Brightness, IPS
5.	RESOLUTION	S - 1024 x 600 px
6.	INTERFACE	T - TFT LCD, RGB
7.	FRAME	N - Without Mounting Metal Frame
8.	BACKLIGHT TYPE	W - LED White
9.	TOUCH PANEL	N - Without Capacitive Touch Panel
10.	VERSION	00 - version
11	MODULE REVISION	V1.1A

Revision:	Changes:	Date:
1.0	Initial Case	2026.03.19

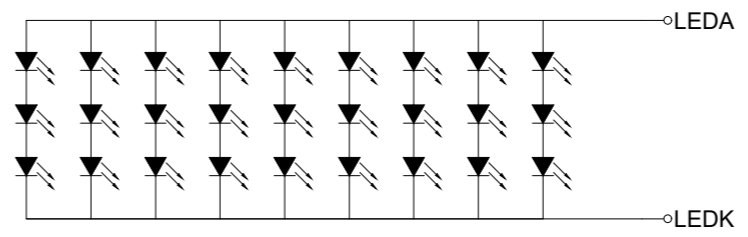
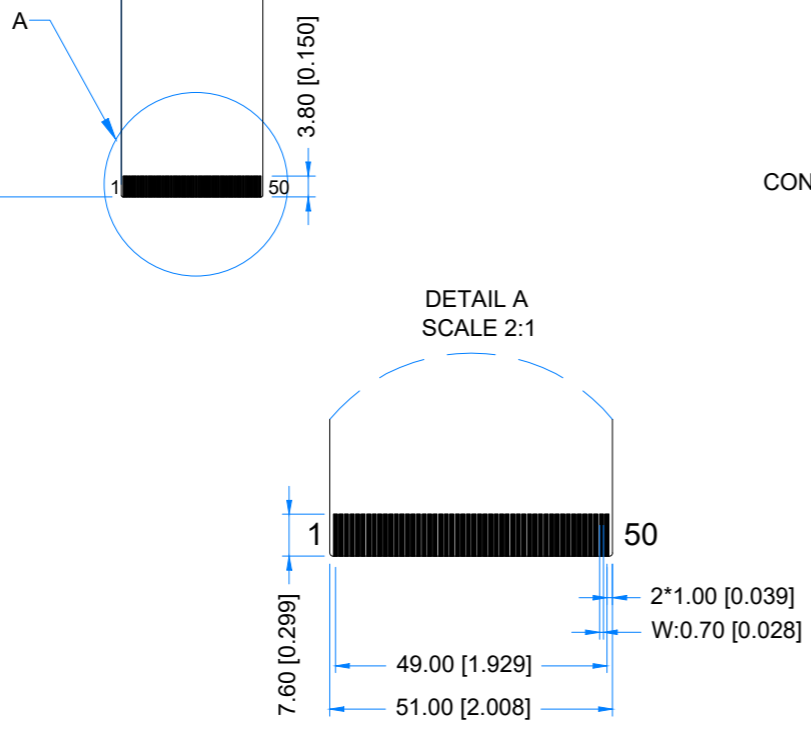
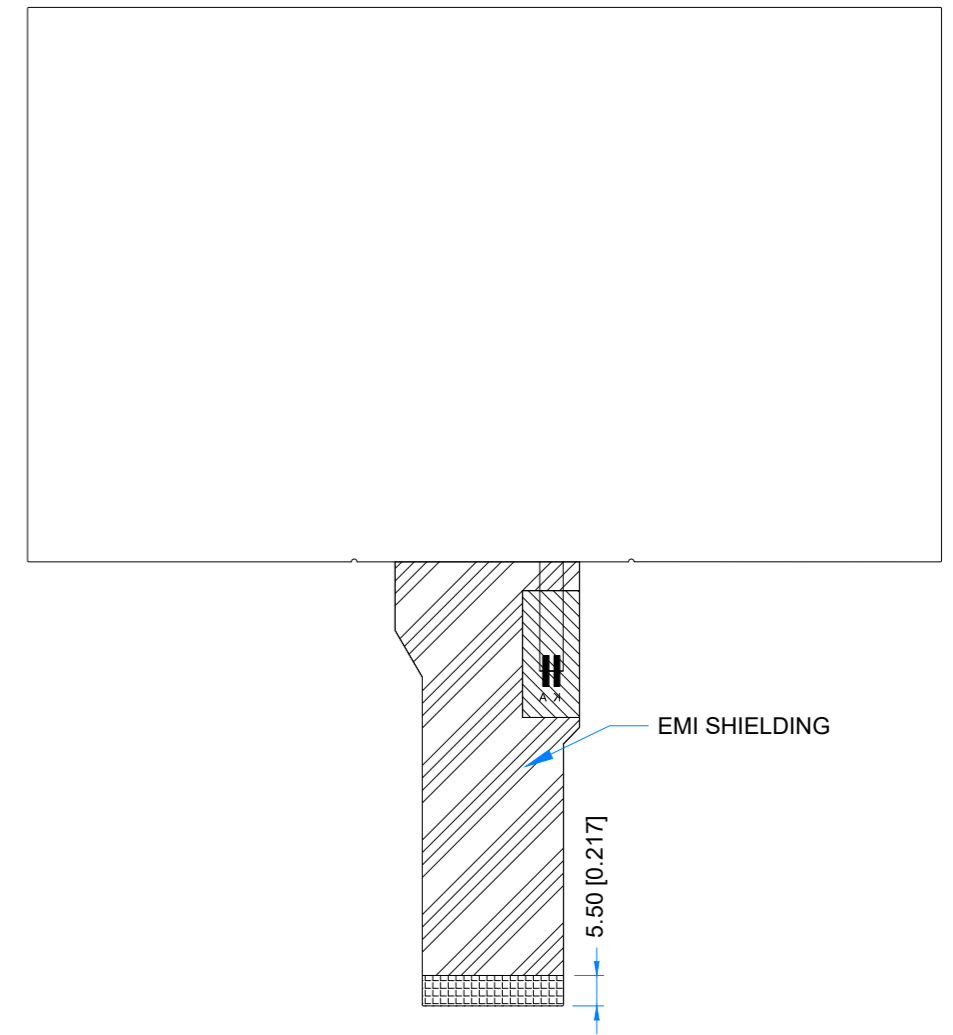
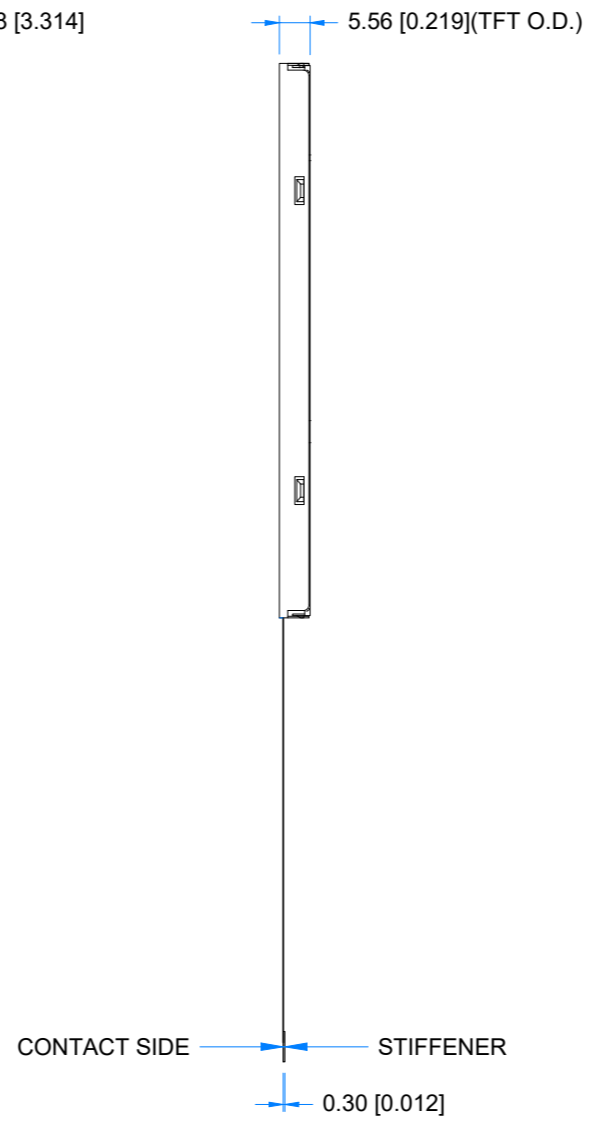
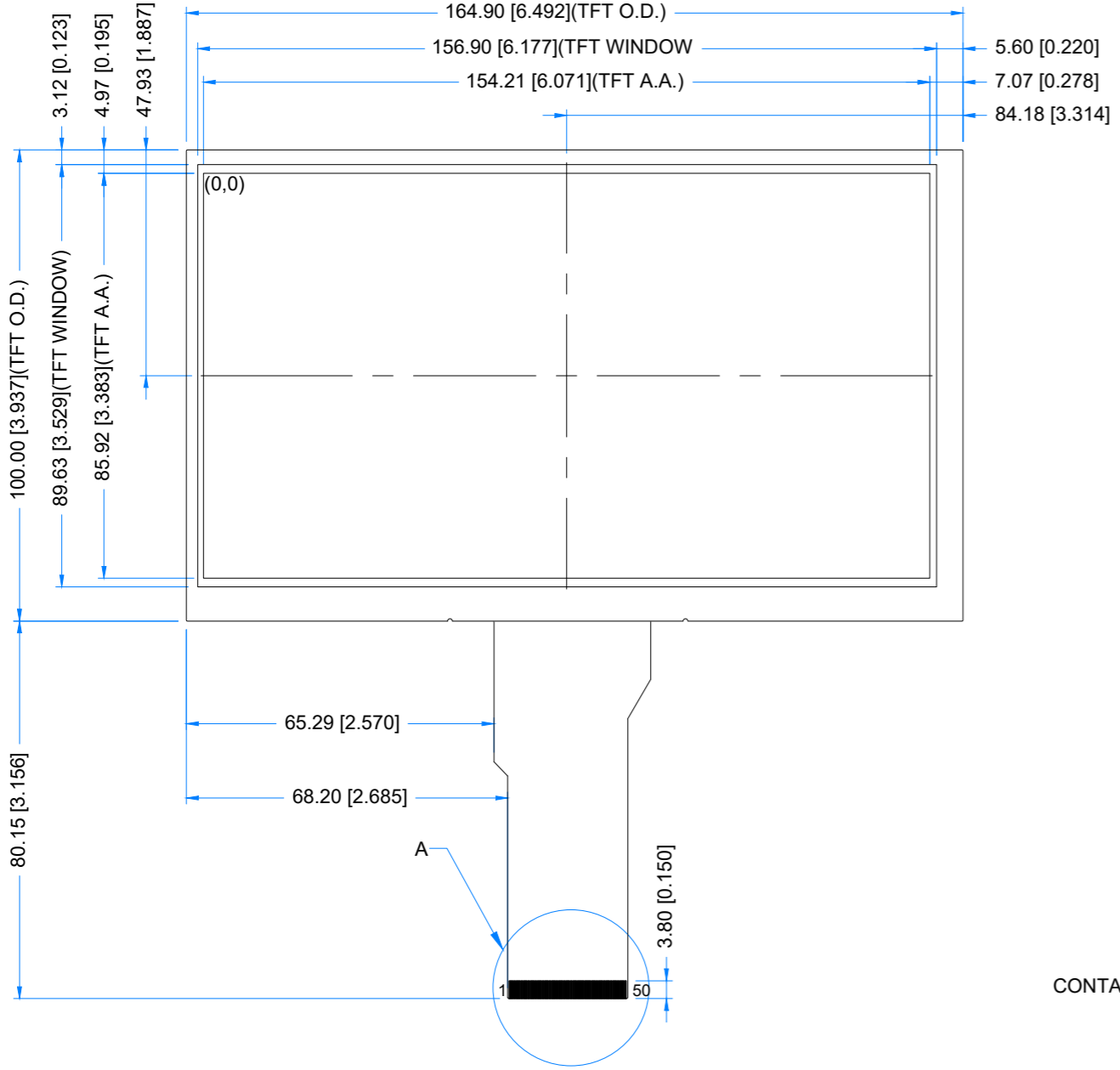

LED Diagram Circuit

TFT NOTES:
1. LCD TYPE: TRANSMISSIVE, NORMALLY BLACK,IPS
2. RESOLUTION: 1024x600
3. VIEWING ANGLE: FREE
4. IC CONTROLLER:EK79001HK+EK73215BCGA
5. OPERATING VOLTAGE: 3.3V
6. INTERFACE: RGB
7. BACKLIGHT: 27 LEDS WHITE, Vf = 8.4-10.2V, If = 270mA

GENERAL NOTES:
1. MODULE SURFACE LUMINANCE: 1000cd/m²
2. OPERATING TEMPERATURE: -20°C ~ 70°C
3. STORAGE TEMPERATURE: -30°C ~ 80°C
4. WITHOUT INDIVIDUAL TOLERANCE: ±0.3mm
5. RoHS3 COMPLIANT

PN: RVT70HSTNWN00 V1.1A
SN:
DRAWN: M.Stabinski 2026.03.19
CHECKED: M.Wierzbowski 2026.03.19
APPR: M.Wierzbowski 2026.03.19



2026.03.19 1:1.36
[mm]
ISO A3 P. 1 of 1

5. ABSOLUTE MAXIMUM RATINGS

PARAMETER	SYMBOL	MIN	MAX	UNIT	REMARK
Analog supply voltage	V_{CI}	-0.3	+3.6	V	-
Backlight Forward Current	I_F	-	40	mA	For each serial LED
Operating Temperature	T_{OP}	-20	70	°C	-
Storage Temperature	T_{ST}	-30	80	°C	-

Note. The above are maximum values. If exceeded, they may cause permanent damage to the unit.

6. ELECTRICAL CHARACTERISTICS

PARAMETER		SYMBOL	MIN	TYP	MAX	UNIT	REMARK
Digital supply voltage		V_{DD}	3.0	3.3	3.6	V	-
		A_{VDD}	8.9	9.0	9.1	V	
		V_{GH}	17	18	19	V	
		V_{GL}	-6.5	-6.0	-5.5	V	
		V_{COM}	3.0	3.15	3.3	V	
Input Signal Voltage	Low Level	V_{IL}	0	-	$0.3V_{DD}$	V	RXIN0- ,RXIN0+,RXI N1- ,RXIN1+,RXI N2- ,RXIN2+SELB ,RESET,STBY B,L/R,U/D
	High Level	V_{IH}	$0.7V_{DD}$	-	V_{DD}	V	

7. BACKLIGHT ELECTRICAL CHARACTERISTICS

PARAMETER	SYMBOL	MIN	TYP	MAX	UNIT	NOTE
Backlight Driving Voltage	V_F	8.4	9.0	10.2	V	Notes 1, 2
Backlight Driving Current	I_F	-	270	-	mA	
Backlight Power Consumption	W_{BL}	-	2430	-	mW	
Backlight Lifetime	-	-	30,000	-	hours	Note 3

Note 1: The LED driving condition is defined for total backlight consumption, and which depend on Forward Current setting.

Note 2: Forward Voltage is just for reference for one serial.

Note 3: The “Operating lifetime” is defined as the module brightness decrease to 50% original brightness at $T_a=25^{\circ}\text{C}$ and $I_F=270\text{mA}$. The LED lifetime could be decreased if operating I_F is larger than 270mA.

8. ELECTRO-OPTICAL CHARACTERISTICS

ITEM	SYMBOL	CONDITION	MIN	TYP	MAX	UNIT	RMK	NOTE
Response Time	Tr+Tf	$\theta=0^\circ$ $\phi=0^\circ$ Ta=25 °C	-	27	45	ms	FIG 2.	4, 7
Contrast Ratio	Cr		600	800	-	---	FIG 3.	1, 7
Surface Luminance	Lv		-	1000	-	cd/m ²		2, 7
Uniformity	U	-	70	75	-	%	FIG 3.	3
Viewing Angle Range	θ	$\phi = 90^\circ$	80	85	-	deg	FIG 4.	6
		$\phi = 270^\circ$	80	85	-	deg		
		$\phi = 0^\circ$	80	85	-	deg		
		$\phi = 180^\circ$	80	85	-	deg		
CIE (x, y) Chromaticity	Rx	$\theta=0^\circ$ $\phi=0^\circ$ Ta=25 °C	0.581	0.611	0.641	-	FIG 3.	5,7
	Ry		0.295	0.325	0.355	-		
	Gx		0.306	0.336	0.366	-		
	Gy		0.513	0.543	0.573	-		
	Bx		0.117	0.148	0.178	-		
	By		0.127	0.157	0.187	-		
	Wx		0.291	0.321	0.351	-		
	Wy		0.315	0.345	0.375	-		
NTSC ratio	-	-	40	47	-	%		

Note 1. Contrast Ratio (CR) is defined mathematically as below, for more information see Figure 2.

$$\text{Contrast Ratio} = \frac{\text{Average Surface Luminance with all white pixels (P1, P2, P3, P4, P5)}}{\text{Average Surface Luminance with all black pixels (P1, P2, P3, P4, P5)}}$$

Note 2. Surface luminance is the LCD surface from the surface with all pixels displaying white. For more information see Figure 2.

L_v = Average Surface Luminance with all white pixels (P1, P2, P3, P4, P5)

Note 3. The uniformity in surface luminance δ WHITE is determined by measuring luminance at each test position 1 through 5, and then dividing the minimum luminance of 5 points luminance by maximum luminance of 5 points luminance. For more information see Figure 2.

$$\delta \text{ WHITE} = \frac{\text{Minimum Surface Luminance with all white pixels (P1, P2, P3, P4, P5)}}{\text{Maximum Surface Luminance with all white pixels (P1, P2, P3, P4, P5)}}$$

Note 4. Response time is the time required for the display to transition from white to black (Rise Time, T_r) and from black to white (Decay Time, T_f). For additional information see Figure 1. The test equipment is BM-7A.

Note 5. CIE (x, y) chromaticity, the x, y value is determined by measuring luminance at each test position 1 through 5, and then make average value.

Note 6. For TFT module, viewing angle is the angle at which the contrast ratio is greater 10. The angles are determined for the horizontal or x axis and the vertical or y axis with respect to the z axis which is normal to LCD surface. For more information see Figure 3.

Note 7. Viewing angle is measured at the center point of the LCD by CONOSCOPE (ergo-80). For response time testing, the testing data is based on BM-7A. Instruments for Contrast Ratio, Surface Luminance, Luminance Uniformity, Chromaticity the test data is based on SR-3A.

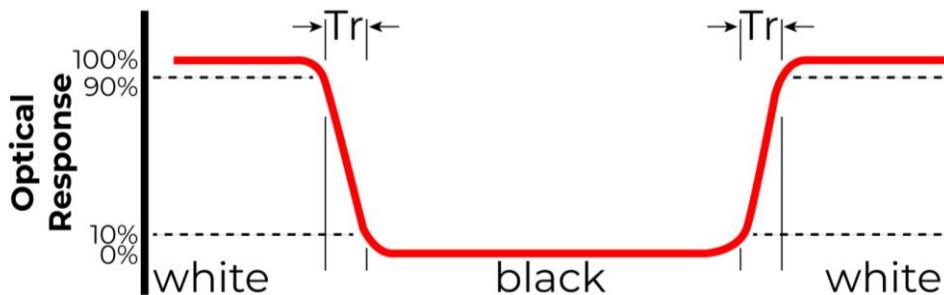

Figure 1. The definition of response time

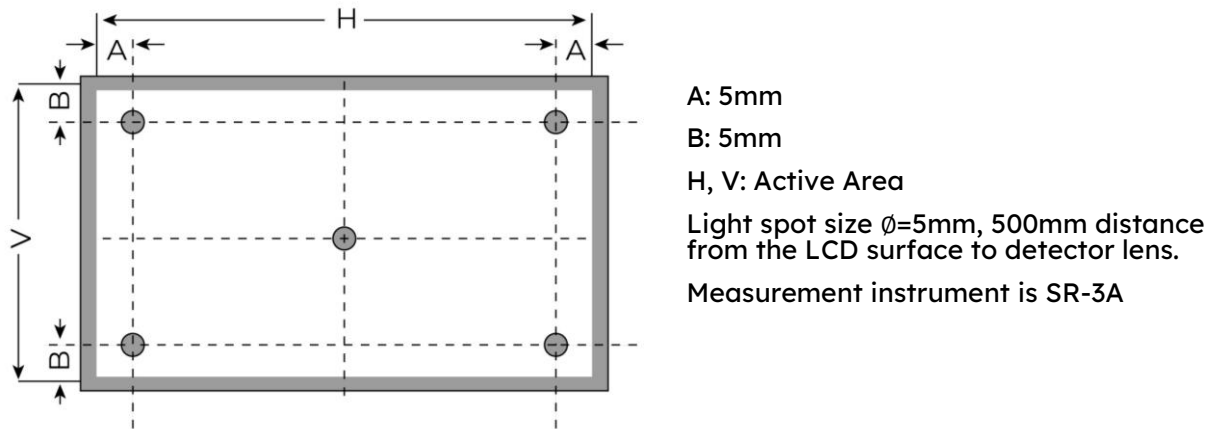

Figure 2. Measuring method for Contrast ratio, surface luminance, Luminance uniformity, CIE (x, y) chromaticity

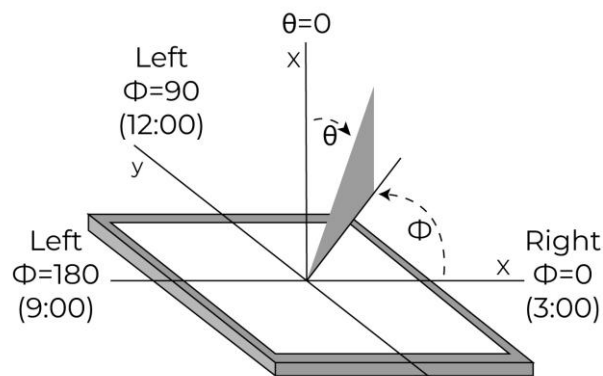

Figure 3. The definition of viewing angle

9. INTERFACES DESCRIPTION

9.1 TFT ASSIGNMENT

PIN	SYMBOL	I/O/P	DESCRIPTION
1	VLED+	P	Power for LED backlight (Anode)
2	VLED+	P	Power for LED backlight (Anode)
3	VLED-	P	Power for LED backlight (Cathode)
4	VLED-	P	Power for LED backlight (Cathode)
5	GND	P	Ground
6	VCOM	P	Common voltage
7	DVDD	P	Power for Digital Circuit
8	MODE	I	DE/SYNC mode select
9	DE	I	Data Input Enable
10	VS	I	Vertical Sync Input
11	HS	I	Horizontal Sync Input
12-19	B7-B0	I	Blue data
20-27	G7-G0	I	Green data
28-35	R7-R0	I	Red data
36	GND	P	Ground
37	DCLK	I	Sample Clock
38	GND	P	Ground
39	L/R	I	Left/right selection
40	U/D	I	Up/down selection
41	VGH	P	Gate ON voltage
42	VGL	P	Gate OFF voltage

43	AVDD	P	Power for Analog Circuit
44	RESET	I	Global reset pin
45	STBYB	I	ON display and OFF display
46	VCOM	P	Common voltage
47	DITHB	I	Dithering function
48	GND	P	Ground
49-50	NC	-	No connection

10. TIMING CHART

10.1 Vertical Input Timing

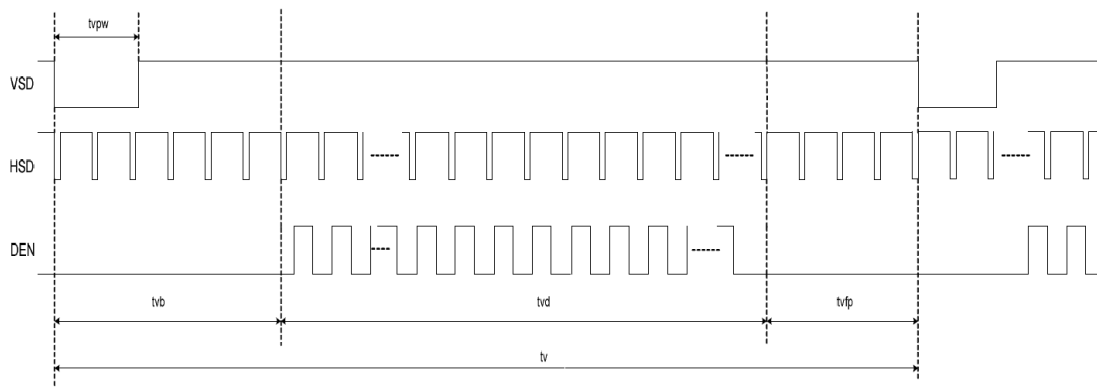

10.2 Horizontal Input Timing

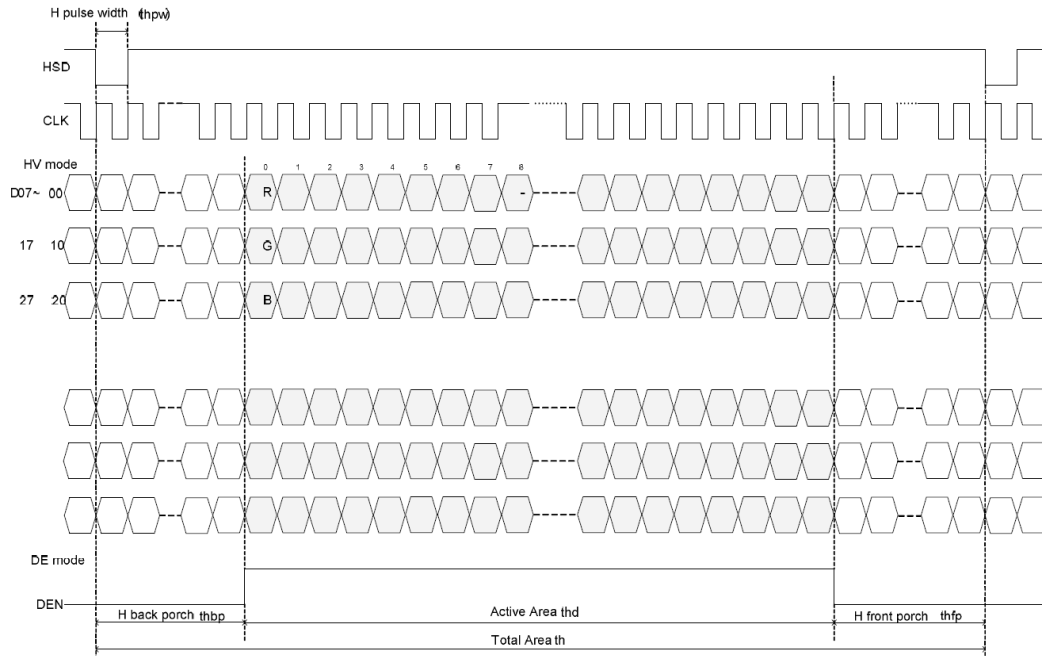

10.3 Parallel RGB Timing Characteristic

10.3.1 DE Mode

PARAMETER	SYMBOL	MIN	TYP	MAX	UNIT
DCLK frequency @Frame rate=60HZ	fclk	40.8	51.2	67.2	MHz
Horizontal display area	Thd	1024			DCLK
HSYNC period time	Th	1114	1344	1400	DCLK
HSYNC blanking	Thb+thfp	90	320	376	DCLK
Vertical display area	Tvd	600			H
VSYNC period time	Tv	610	635	800	H
VSYNC blanking	Tvb+tvfp	10	35	200	H

10.3.2 HV Mode (Horizontal input timing)

PARAMETER	SYMBOL	MIN	TYP	MAX	UNIT
DCLK frequency @Frame rate=60Hz	Fclk	44.9	51.2	63	MHz
Horizontal display area	Thd	1024			DCLK
1 Horizontal line	Th	1200	1344	1400	DCLK
HSYNC Pulse Width	Thpw	1	-	140	DCLK
HSYNC back porch	Thbp	160	160	160	DCLK
HSYNC front porch	Thfp	16	160	216	DCLK

10.3.3 HV Mode (Vertical input timing)

PARAMETER	SYMBOL	MIN	TYP	MAX	UNIT
Vertical display area	Tvd	600			H
1 VSYNC period time	Tv	624	635	750	H
VSYNC Pulse Width	Tvpw	1	-	20	H
VSYNC back porch	Tvbp	23	23	23	H
VSYNC front porch	Tvfp	1	12	127	H

11. INSPECTION

Standard acceptance/rejection criteria for TFT module according to document available [here](#).

12. RELIABILITY TEST

NO.	TEST ITEM	TEST CONDITION	NOTE
1	High Temperature Storage	80°C/120 hours	A,B,C,D,E
2	Low Temperature Storage	-30°C/120 hours	
3	High Temperature Operating	70 °C /120 hours	
4	Low Temperature Operating	-20°C/120 hours	
5	High Temperature and High Humidity	+60°C, 90%RH, 120hrs	
6	Thermal Cycling Test (No operation)	-20°C/30 min ~ +70°C/30 min for a total 10 cycles, Start with cold temperature and end with high temperature.	A,B,C,D,E
7	Vibration Test	Sweep:10Hz~55Hz~10Hz 2G 2 hours for each direction of X. Y. Z. (6 hours for total)	A,B,C,D,E
8	Package Vibration Test	Random Vibration : 0.015G*G/Hz from 5-200HZ, -6dB/Octave from 200-500HZ 2 hours for each direction of X. Y. Z. (6 hours for total)	A,B,C,D,E
8	Package Drop Test	Height: 60 cm 1 corner, 3 edges, 6 surfaces	A,B,C,D,E
9	ESD	Contact=+/-2KV, Air=+/-4KV,(R=330R,C=150pF), 1 sec,9point,10times/point;	A,B,C,D,E

Notes

- A. LCM each function is OK.
- B. LCM appearance inspection without abnormalities (Including scratch, damage, corrosion and serious deformation)
- C. LCM brightness above the Min. value of Spec.
- D. Luminance uniformity above the Min. value of Spec.
- E. Color chromaticity within tolerance range.

13. LEGAL INFORMATION

CE marking is usually obligatory only for a complete end product. Riverdi display modules are semi-finished goods which are used as inputs to become part of the finished products.

Therefore, Riverdi display modules are not CE marked.

This is not a standalone product. It was designed as an electronic component. It needs integration with a whole system to be fully functional.

Riverdi grants the guarantee for the proper operation of the goods for a period of 12 months from the date of possession of the goods. If in a consequence of this guaranteed execution the customer has received the defects-free item as replacement for the defective item, the effectiveness period of this guarantee shall start anew from the moment the customer receives the defects-free item.

Information about device is the property of Riverdi and may be the subject of patents pending or granted. It is not allowed to copy or disclosed this document without prior written permission.

Riverdi endeavors to ensure that all contained information in this document is correct but does not accept liability for any error or omission. Riverdi products are in developing process and published information may be not up to date. Riverdi reserves the right to update and makes changes to Specifications or written material without prior notice at any time. It is important to check the current position with Riverdi.

Images and graphics used in this document are only for illustrative the purpose. All images and graphics are possible to be displayed on the range products of Riverdi, however the quality may vary. Riverdi is no liable to the buyer or to any third party for any indirect, incidental, special, consequential, punitive, or exemplary damages (including without limitation lost profits, lost savings, or loss of business opportunity) relating to any product, service provided or to be provided by Riverdi, or the use or inability to use the same, even if Riverdi has been advised of the possibility of such damages.

Riverdi products are not fault tolerant nor designed, manufactured or intended for use or resale as on line control equipment in hazardous environments requiring fail-safe performance, such as in the operation of nuclear facilities, aircraft navigation or communication systems, air traffic control, direct life support machines or weapons systems in which the failure of the product could lead directly to death, personal injury or severe physical or environmental damage ('High-Risk Activities'). Riverdi and its suppliers specifically disclaim any expressed or implied warranty of fitness for High-Risk Activities. Using Riverdi products and devices in 'High-Risk Activities' and in any other application is entirely at the buyer's risk, and the buyer agrees to defend, indemnify and hold harmless Riverdi from all damages, claims or expenses resulting from such use. No licenses are conveyed, implicitly or otherwise, under any Riverdi intellectual property rights.

14. CONTACT

Your Success is Our Priority

Stuck on a technical challenge? Need expert guidance?
Our dedicated support team is just a message away.

Contact us at

contact@riverdi.com

We're here to ensure your project's success, every step of the way!